

## OSHPD Lateral Brace Clamp Fig. AF776



### Material Specifications

#### Size Range

Service Pipe: 2 1/2" through 8" Carbon Steel  
Brace Pipe: 1" or 1 1/4" Sch. 40

#### Material

Carbon steel

#### Finish

Plain or  
Electro-Galvanized per ASTM B633

#### Service

Designed to rigidly brace piping systems subjected to lateral seismic loads. May also be installed to brace piping systems subjected to vertical seismic loads. For vertical load capacities, reference OSHPD OPM-0351-13.

### Material Specifications (continued)

#### Approvals

FM Approved (FM 1950-10 & FM 1950-13).  
OSHPD Pre-Approved (OPM-0351-13 and  
OPA-2804-10). Complies with the hanging and  
bracing requirements listed in NFPA 13.

#### Features

Visual indication of proper assembly when  
the head of the set screw bottoms out on the  
hoop ends.

#### Installation Instructions:

- Place the OSHPD Lateral Brace Clamp over the service pipe to be braced and slide the Sch. 40 brace pipe through the hoop ends. The end of the brace pipe must extend at least 1" past the hoop ends.
- Note: The brace pipe may be installed above or below the service pipe.
- Ensure brace pipe is set to the desired installation brace angle.
- Torque the set screws alternately and equally until the head of the set screw bottoms out on the hoop ends.
- For riser/4-way brace installations, two OSHPD Lateral Brace Clamps must be installed within 6" of each other.
- Fire Protection applications shall also be installed per the requirements of NFPA 13 and local codes.

#### Ordering

Specify service pipe size, brace pipe size, figure number, finish and description.

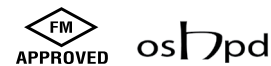

PROJECT INFORMATION	APPROVAL STAMP
Project:	Approved
Address:	Approved as noted
Contractor:	Not approved
Engineer:	Remarks:
Submittal Date:	
Notes 1:	
Notes 2:	

## OSHDP Lateral Brace Clamp Fig. AF776

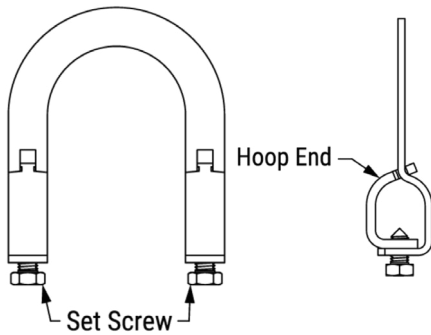

### Dimensions (In) • Weight (Lbs)

Service Pipe Size	Weight	
	1" Brace Pipe	1 ¼" Brace Pipe
2 ½	1.26	1.50
3	1.44	1.58
4	1.55	1.68
5	1.66	1.87
6	1.74	1.95
8	1.98	2.29

### Notes

ASC Engineered Solutions™ brand bracing components are designed to be compatible ONLY with other ASC Engineered Solutions brand bracing components, resulting in a Listed seismic bracing assembly. Updated FM approval information may be viewed at [www.approvalguide.com](http://www.approvalguide.com).

### Disclaimer

ASC Engineered Solutions does not provide any warranties and specifically disclaims any liability whatsoever with respect to ASC Engineered Solutions bracing products and components that are used in combination with products, parts or systems not manufactured or sold by ASC Engineered Solutions. In no event shall ASC Engineered Solutions be liable for any incidental, direct, consequential, special or indirect damages or lost profits where non-ASC Engineered Solutions bracing components have been, or are used.

**SeisBrace® Seismic Fire Protection Design Tool may be accessed at [www.seisbrace.com](http://www.seisbrace.com)**

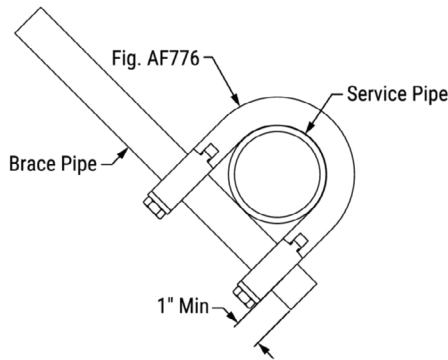

### FM Max Seismic Lateral ASD Loads\*\*\*: Dimensions (In) • Load (Lbs) • Angles (Deg)

Service Pipe Size	Brace Pipe Size	Pipe Schedules	Max Seismic Brace Load at Brace Pipe Angle**			
			30-44	45-59	60-74	75-90
2 ½		LW*	600	850	1040	1160
		Sch. 10 – Sch. 40	620	880	1080	1200
3		LW*	520	740	910	1010
		Sch. 10 – Sch. 40	620	880	1080	1200
4	1 – 1 ¼	LW*	520	740	910	1010
		Sch. 10 – Sch. 40	690	980	1200	1340
5		LW*	520	740	910	1010
		Sch. 10 – Sch. 40	670	940	1160	1290
6		LW*	560	790	970	1080
		Sch. 10 – Sch. 40	670	940	1160	1290
8		Sch. 10 – Sch. 40	540	770	940	1050

\* Load rating for LW above refers to FM Approved Lightwall pipe, commonly referred to as Sch.7 and Flow Pipe. See FM Approval Guide for approved Lightwall pipe.

\*\* Brace Pipe Angles are determined from vertical.

\*\*\* The allowable FM approved capacity of brace subassemblies are listed in Allowable Stress Design (ASD). For Load Resistance Factor Design (LRFD) capacities, the above values will need to be multiplied by 1.5.



[asc-es.com](http://asc-es.com)

Building connections that last™